

MARK	REVISIONS NO	REASONABLE RVISIONS	DATE	DWN	APVD

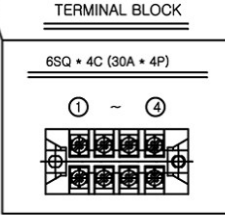
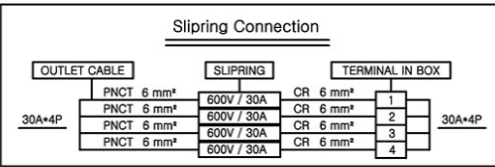
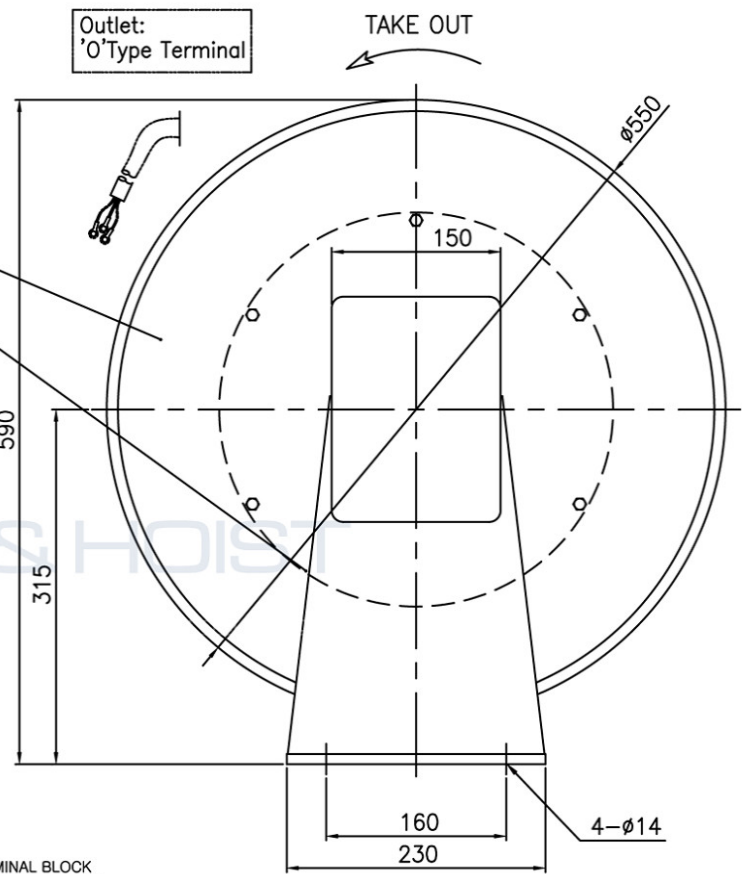
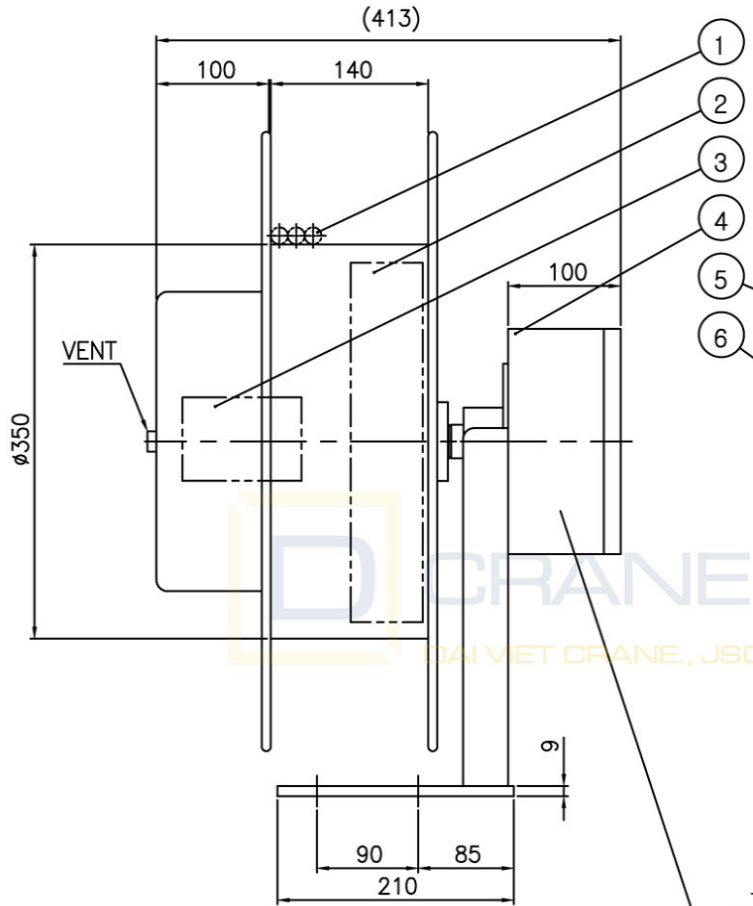
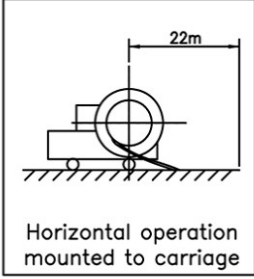
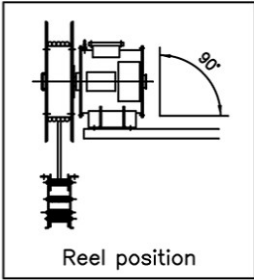
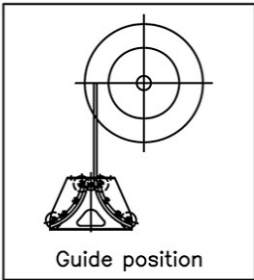

SPECIFICATION

- 1. Cable
 - o PNCT 6sq x 4c
 - o Size : approx. 17.6mm
 - o Weight : approx. 0.51kg/m
 - o Length : 22 M
- 2. Winding Length : 22 M
- 3. Winding Speed : max. 20 M/MIN
- 4. Winding Torque : 2 Kg.m
- 5. Slip Ring : 30A x 4P
- 6. Paint Color : MUNSELL No. 7.5 BG6/1.5(60um)
- 7. Setting Height : Max. 2.0 m from G.L.
- 8. Q' ty : 1 Set
- 9. Weight : - Kg

6	FRAME	SPHC	1		
5	DRUM	SPCC	2		
4	TERMINAL BOX	PLASTIC	1		
3	SLIP RING	C3771	4		
2	SPRING	ATX	2		
1	CABLE	PNCT	25M		
ITEM 순번	PARTS NO. 품번	PART NAME 품명	MATERIAL 재질	Q'TY 수량	REMARKS 비고
PROJECTION 3rd ANGLE		DIMENSIONS METRIC (mm)		SCALE 1 : 7	MODEL ECC-625-4
CUSTOMER 고객			PART NAME ASS'Y		
MODEL COLOR 제품 색상		7.5 BG6/1.5		PART NO. Z825-7000	
DRAWING		DESIGN	CHECK	APPROVAL	
SIGN		P.S.Y			
DATE		2017.3.7			



A4(210X297)